

**oerlikon**  
leybold vacuum

# DURADRY

Dry Compressing Vacuum Pump  
for Photovoltaic and  
Semi-conductors Applications

171.07.02

Excerpt from the Oerlikon Leybold Vacuum Full Line Catalog

Product Section C05

Edition March 2008

# Contents

## General

Applications ..... C05.02  
 General ..... C05.03

## Products

Dry Compressing Vacuum Pump DURADRY ..... C05.04

# Applications

Pumps	DURADRY 105	DURADRY 255
<b>Process</b>		
Load lock chamber	■	■
Transfer chamber	■	■
Inspection	■	■
Etch	■	■
Metallic film deposition		
PVD	■	■
CVD-W, WSi, WN	■	■
CVD-Ti, TiN	■	■
CVD-Al	■	■
ALD	■	■
Dielectric film deposition		
LP CVD	■	■
PE CVD	■	■
ALD	■	■

# General

## DURADRY Dry Compressing Vacuum Pumps for Photovoltaic and Semi-conductor Applications

### Operating Principle

The dry compressing DURADRY vacuum pump has been designed for operation in connection with processes related to the production of semiconductor chips, displays and solar modules.

Oerlikon Leybold Vacuum has revolutionised the dry compressing screw technology through the introduction of an innovative double flow pump. The pump unit consists of two screw rotors with a centre inlet. The rotors revolve in opposite directions thereby conveying the gas from the centre of the rotor to both ends of the vacuum housing.

PFPE (perfluoropolyether) oil is used to lubricate both bearings which support the shaft ends of both rotors. Also the gear through which the rotors are driven is lubricated with the PFPE oil. A well tried and tested piston ring seal ensures a reliable separation of the gear chamber from the pump chamber of the pump and prevents the ingress of PFPE oil.

By cooling the pump housing with water and by cooling the rotors with oil, the temperature can be optimally matched to differing applications. Cooling of the rotors allows for very low surface temperatures which, in particular when pumping thermally unstable gases is of great advantage. Owing to the use of a purge gas, the formation of particles as well as the condensation of vapours can be effectively prevented.

### Advantages to the User

- The short gas passage from the inlet of the pump to its exhaust reduces the dwell time of the gas thereby also reducing the formation of particles within the pump
- The double flow design minimises wear on the bearings thereby extending the intervals between servicing
- The bearings which are constantly lubricated with oil extend bearing service life by a factor of 3 compared to grease lubricated bearings
- The oil cooled rotors ensure a uniform temperature spread within the pump and permit the temperature of the pump to be controlled within a wide temperature range
- The well tried and tested non-contact piston ring seals offer an unlimited service life
- The integrated electronics and sensors allow the pump to be easily integrated within the system controller
- Your expectations:
  - Pumping of reactive process gases
  - Integrated monitoring and control
  - Compact pump systems
  - Simple matching to different process requirements
- Your expectations:
  - Pumping speed of 100 and 225 m<sup>3</sup>/h
  - Pump combinations up to 1800 m<sup>3</sup>/h
  - Integrated monitoring of all important operating parameters
  - Adjustable temperature and purge gas flow
  - Controller for the Roots pump integrated within the electronics

### Typical Applications

- Coating technology for the semiconductor industry, for displays and photovoltaic systems

### Accessories

For faultless operation of the DURADRY in connection with different processes, Oerlikon Leybold Vacuum has developed a variety of accessories.

- For processes involving a high particle count, Oerlikon Leybold Vacuum offers particle filters both for the intake and also for the exhaust side.
- For pumping of thermally unstable substances we recommend to install on the intake side a heated trap, and by means of an additional cooling unit the surface temperature of the pump can be reduced.
- Heating the exhaust line can effectively prevent any condensation of humidity and other condensable gases.

Accessories matched to specific customer requirements are available upon request.

# Products

## DURADRY 105 and 255



DURADRY 105

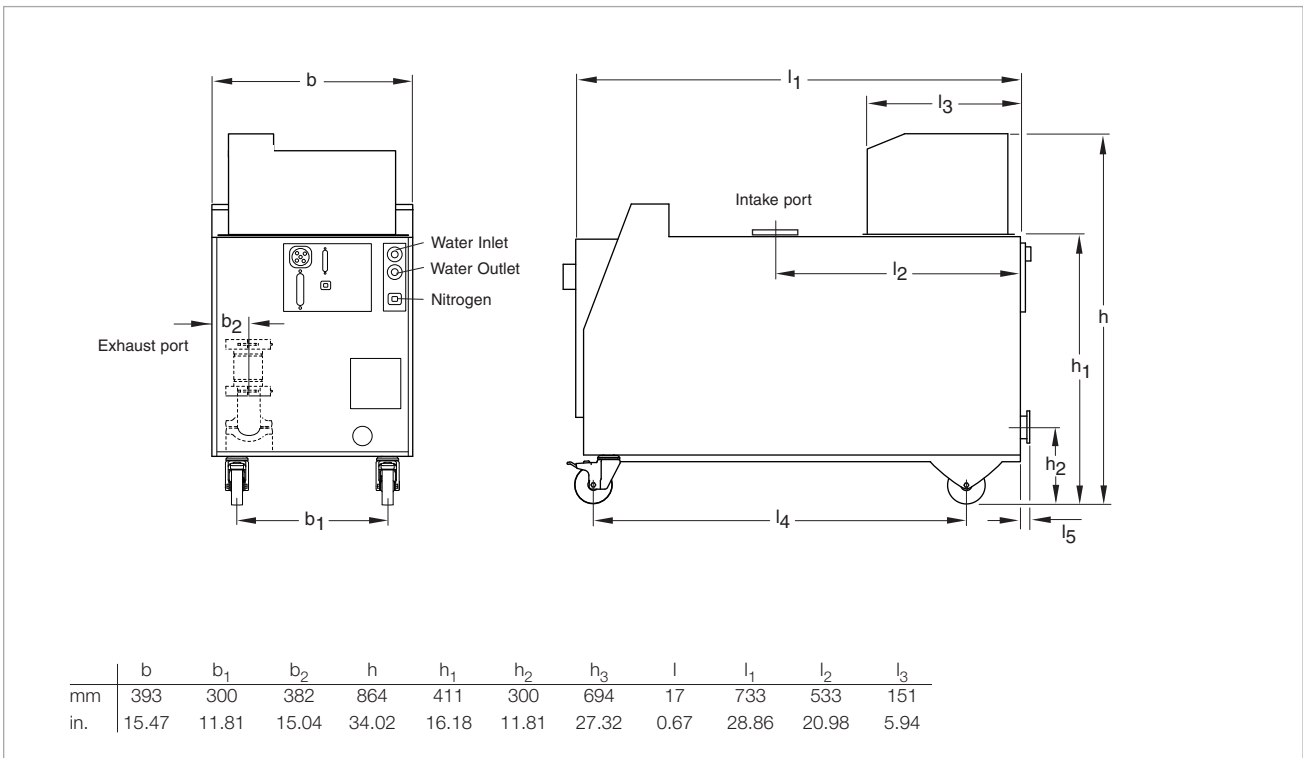

Dimensional drawing for the DURADRY 105; 255 identical

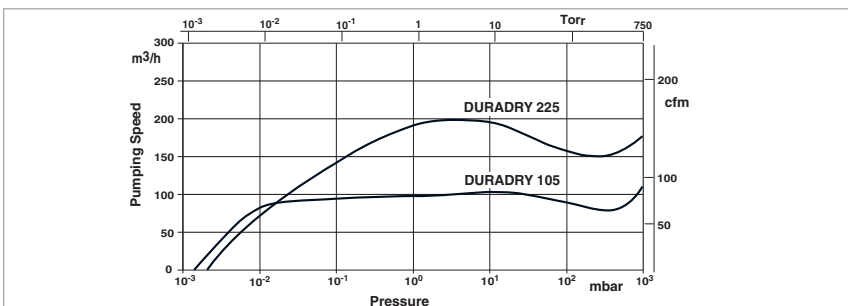

Pumping speed curves for the DURADRY 105 and 255

## Technical Data

### DURADRY 105

### DURADRY 255

Pumping speed 60 Hz operation	$\text{m}^3 \times \text{h}^{-1}$ (cfm)	105 (62)	255 (150)
Ultimate pressure with full CVD purge, 60 Hz operation	mbar (Torr)	$7 \times 10^{-3}$ ( $5.0 \times 10^{-3}$ )	$5 \times 10^{-3}$ ( $3.75 \times 10^{-3}$ )
Maximum intake pressure in continuous operation	mbar (Torr)	1000 (760)	1000 (760)
Maximum exhaust pressure	bar (psig)	1.5 (7.2)	1.5 (7.2)
Nitrogen supply pressure	bar	4 to 8 (43 to 100 psig), (400 to 800 KPa), (4 to 8 kg/cm <sup>2</sup> )	4 to 8 (43 to 100 psig), (400 to 800 KPa), (4 to 8 kg/cm <sup>2</sup> )
Internal purge gas pressure	bar (psig)	3 (29)	3 (29)
Nitrogen consumption			
Etch	slm	12	12
CVD	slm	50	50
Nitrogen connection	NPT	3/8" with 1/4" tube connector	3/8" with 1/4" tube connector
Cooling water requirements, approx.			
Cooling water flow	l/min	1.8 to 2.8	1.8 to 2.8
Cooling water temperature	°C (°F)	15 to 30 (59 to 86)	15 to 30 (59 to 86)
Cooling water pressure at $\Delta P$ 1 bar (15 psig)	bar (psig)	3.5 to 9 (36 to 116)	3.5 to 9 (36 to 116)
Cooling water connection	NPT	1/2 " with 3/8" tube connector	1/2 " with 3/8" tube connector
Intake port	DN	63 ISO-K	63 ISO-K
Exhaust port	DN	40 KF	40 KF
Dimensions (W x H x L)	mm (in.)	400 x 596 x 987 (15.75 x 23.46 x 38.86)	400 x 596 x 987 (15.75 x 23.46 x 38.86)
Weight	kg (lbs)	278 (612)	278 (612)
Maximum ambient temperature	°C (°F)	40 (104)	40 (104)
Minimum ambient temperature	°C (°F)	10 (50)	10 (50)
Typical power consumption	kW (HP)	4.0 (5.4)	4.0 (5.4)
Typical motor power	kW (HP)	5.0 (6.8)	5.0 (5.4)
Supply voltage - Multi voltage motor <sup>1)</sup>		200/208/230/460/480 V ( $\pm 10\%$ ), 3-ph, 60 Hz <sup>1)</sup> or 210/415 V ( $\pm 10\%$ ), 3-ph, 50 Hz <sup>1)</sup>	200/208/230/460/480 V ( $\pm 10\%$ ), 3-ph, 60 Hz <sup>1)</sup> or 210/415 V ( $\pm 10\%$ ), 3-ph, 50 Hz <sup>1)</sup>
Motor rotation speed (nominal) 60 Hz	U/min (rpm)	3600 (3600)	3600 (3600)
Short circuit interrupt capacity (SCIC)	kA	100	100
PFPE oil quantity in gear box	l	1.1	1.1

<sup>1)</sup> The DURADRY models are voltage specific for either low voltage (200 V - 230 V) or high voltage (380 V - 460 V) and are not to be field configured from the factory preset voltage operation.

**Ordering Information****DURADRY 105****DURADRY 255**

DURADRY		
Load Lock		
Low Voltage	<b>Part No. 280 000</b>	-
High Voltage	<b>Part No. 280 001</b>	-
P-Etch		
Low Voltage	<b>Part No. 280 010</b>	-
High Voltage	<b>Part No. 280 011</b>	-
P-CVD		
Low Voltage	<b>Part No. 280 013</b>	-
High Voltage	<b>Part No. 280 014</b>	-
High Voltage with FU	<b>Part No. 280 015</b>	<b>Part No. 280 045</b>
Accessories	<b>upon request</b>	<b>upon request</b>